



*A little bit of satellite
goes a long way*

SC-9A Satellite Terminal

Terminal Features

- Full DISA Certification (Number 06-001)
- Fully Redundant Critical Path Architecture
- 3.0-meter X-Band Antenna
- 250W SSPA
- 500W Power Combined SSPA Option
- Block Up-Converter
- 45K LNA
- Block Down-Converter
- Chain Redundant Up/Down Link Signal Paths
- 125 meter Fiber Optic IFL
- 70/140 MHz to L-band Converter System
- AxxSys® Network Management System (CMAT)
- Regenerative Waveguide Dehydrator



The SC-9A X-Band Satellite Communications terminal features a 3-meter antenna with dual shaped optics, two port feed, and precision tracking system specifically designed to comply with DSCS specifications. The terminal consists of an outdoor equipment group, Inter-facility Link, and indoor equipment group.



The SC-9A terminal's outdoor equipment group is installed within a protective radome structure and includes the 3-meter antenna system and up/downlink RF electronics. The uplink electronics consists of redundant chain switched Block Upconverters & Solid State Power Amplifiers, and the downlink electronics consists of redundant chain switched Low Noise Amplifiers & Block Downconverters. Two transmit power options are available. The standard is redundant 250 watt SSPAs, and the optional configuration is a phase combiner, which provides 500 watts of power by combining the two SSPAs. The RF interfaces to the outdoor equipment group are in the L-band frequency range. The outdoor equipment group also includes ancillary equipment such as a dehydrator system, test loop translator, monitor & control hardware, and prime power distribution.

The indoor equipment group consists of an indoor equipment rack and uninterruptible power system (UPS). The rack contains the DISA certified satellite modems, L-band to 140 MHz frequency converters, antenna tracking controller & receiver, and monitor & control equipment. The rack can also be configured with an optional spectrum analyzer for test and monitoring of various critical signal paths within the system. The UPS provides conditioned power to the SC-9A terminal with a minimum of 10 minutes backup time in the event of a prime power loss.

The L-band and monitor & control connections between the outdoor and indoor equipment groups are made via a multi-core single-mode fiber optic link. This link is configured for redundancy for each signal path including monitor & control.



The redundant solid state and low noise amplifiers mount directly behind the antenna to the feed system. The lower support beam holds the antenna motor control cabinet and regenerative dehydrator.



The Outdoor Equipment Assembly is co-located with the antenna in the radome. This frame includes the Outdoor Signal Enclosure, Block Up Converter, Block Down Converter, Test Loop Translator, Intercom, and Technical and Utility AC Power Panels.



SC-9A X-Band Earth Terminal Specifications

Parameter	Specification
Antenna Subsystem RF Specifications	
TX Antenna Gain Mid-band	45.77 dBi Typical
RX Antenna Gain Mid-band	45.16 dBi Typical
Antenna Sidelobe Envelope Feed	ITU 580, MIL-STD-188
Transmit/Receive Axial Ratio	2-Port Circular TX RH/RX LH field switchable to TX LH/RX RH
Power Handling	1.5 dB
Antenna Tracking Loss	2 KW
	<10% Rx HPBW. 5% typical. Complies with MIL-STD 188-164A.

Uplink Subsystem Specifications

Single Carrier Linear EIRP Mid-band	Baseline: 67.0 dBw. High-Power Option: 70 dBw
HPA Output Power P1dB	Baseline: 250 Watts. High-Power Option: 500 Watts
Frequency Range	7.9 to 8.4 GHz
Frequency Tuning	1 kHz
Gain Adjustment Range	55 dB, 0.1 dB Steps
IF Interface	140 MHz, +/-36 MHz
Transfer Characteristics, Emissions, Gain-Frequency Stability, TX-RX Isolation	Per MIL-STD 188-164A

Downlink Subsystem Specifications

G/T [20 el, +23 C, 45 K LNA, 7.25 GHz]	24.5 dB/K Min, 25.0 Typical (Not including radome loss)
Frequency Range	7.25 to 7.75 GHz
Frequency Tuning	1 kHz
Gain Adjustment Range	35 dB, 0.1 dB Steps
IF Interface	140 MHz, +/-36 MHz or Alternate L-Band 950-1450 MHz
Transfer Characteristics, Emissions, Gain-Frequency Stability, TX-RX Isolation	Per MIL-STD 188-164A

Built In Test Features

Test Loop Translator	725 MHz and 200 MHz Local Oscillators, 30 dB Adjustment Range in 1 dB Steps.
Test Loop Paths	Switching Provided to connect on or off-line uplink components to on or off-line downlink components via the Test Loop Translator.
Monitor Ports	Monitor Port Sample Interfaces are provided for all on or off-line up or downlink components.

Control, Monitor, Alarm, and Test Subsystem (CMAT)

Windows™ based Control, Monitoring, Alarm and Test (CMAT) system that controls, monitors, records, trends and provides measurement capability for all earth station equipment status, alarms, and measurement points.

Power Subsystem

Power Requirements	Technical: Split phase 120/208 VAC, 50/60 Hz, 6 KVA Utility: 3 phase 120/208 VAC, 50/60 Hz, 3 KVA
Uninterruptible Power System	10 minutes backup time for technical load, True On-line Double Conversion operation. Manual Bypass Switch provided.

Environmental Specifications-Indoor Equipment

Operational Temperature	0-40°C
Relative Humidity	To 95%, non-condensing

Environmental Specifications-Outdoor Equipment

Operational Temperature	-40°C to +55°C
Wind	125 mph (Radome performance)
Relative Humidity	Up to 90% at temperatures below 0°C, up to 100% condensing at temperatures above 0°C.

Fully Redundant System architecture for maximum availability.

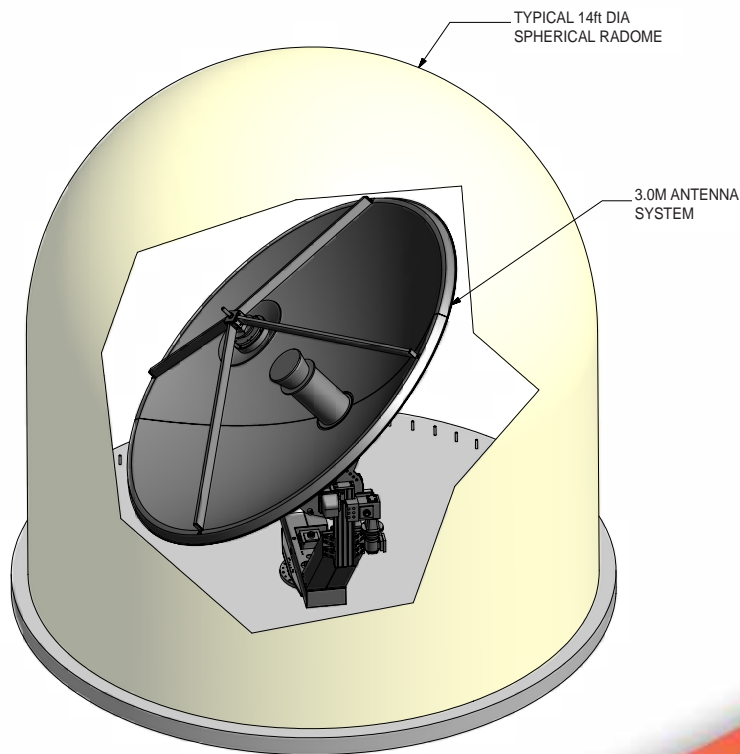
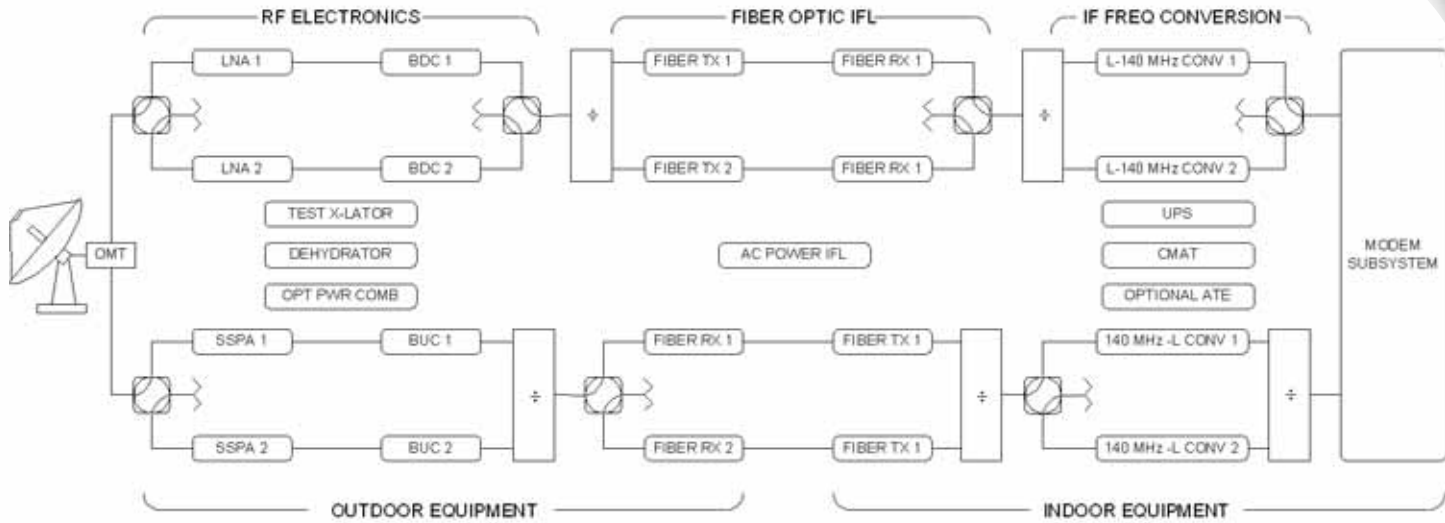

TEL: +1 631 231-9800
<http://www.globecommsystems.com>
 e-mail: info@globecommsystems.com